

Orbis 1



Caractéristiques techniques:

KG	142 kg
PA	12
kW	5
m ²	30-120
Mg/M³	13
	1,53 kg
	81/71 %

Orbis 1

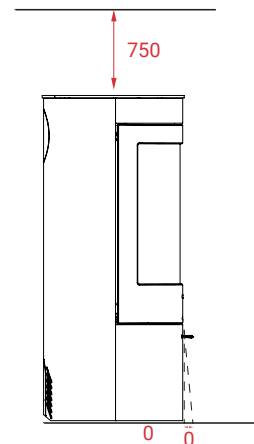
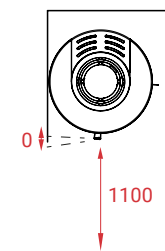
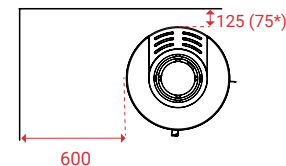
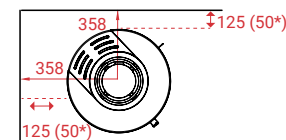
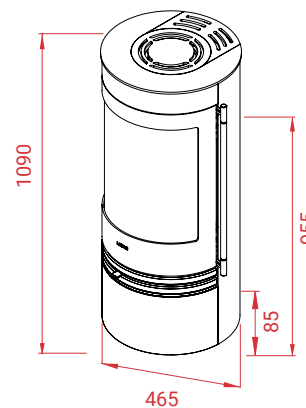

Accessoires:



Autres modèles:

Orbis 2
Orbis 3

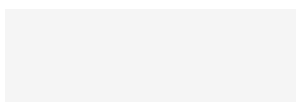

En savoir plus:



LOTUS HEATING SYSTEMS A/S

+45 6323 7070

info@lotusstoves.com

www.lotusstoves.com



Orbis 1 Pierre ollaire



Caractéristiques techniques:

KG	145 kg
PA	12
kW	5
m ²	30-120
Mg/M³	13
	1,53 kg
	81/71 %

Orbis 1 Pierre ollaire

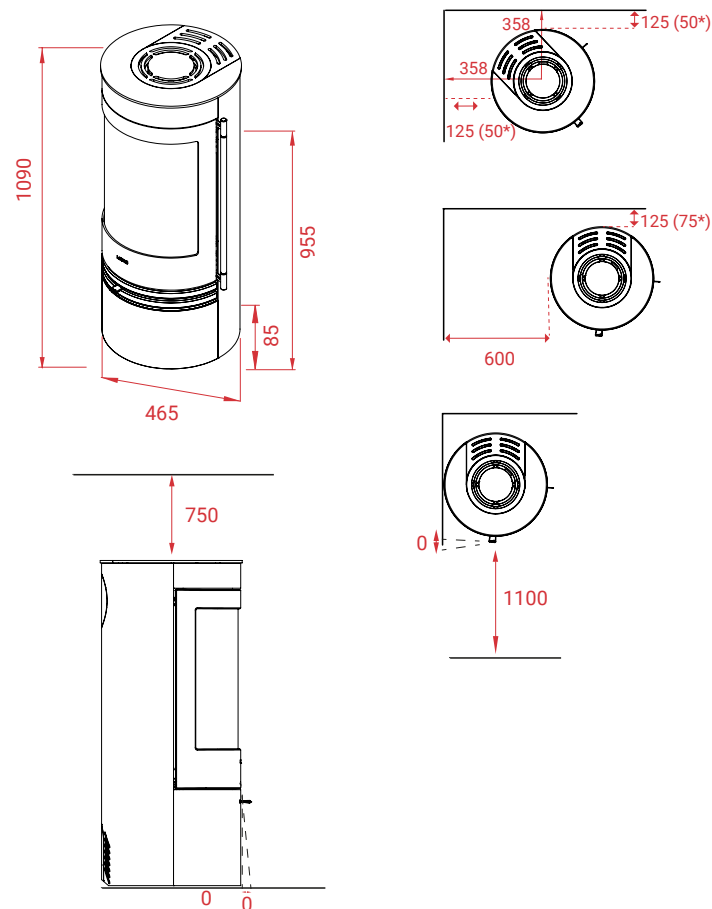

Accessoires:



Autres modèles:

Orbis 2
Orbis 3

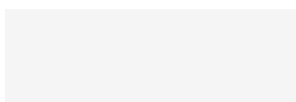

En savoir plus:



LOTUS HEATING SYSTEMS A/S

+45 6323 7070

info@lotusstoves.com

www.lotusstoves.com



Orbis 1 Indian Night



Caractéristiques techniques:

KG	145 kg
PA	12
kW	5
m ²	30-120
Mg/M³	13
	1,53 kg
	81/71 %

Accessoires:



Autres modèles:

Orbis 2
Orbis 3

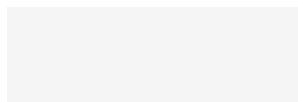

Orbis 1 Indian Night

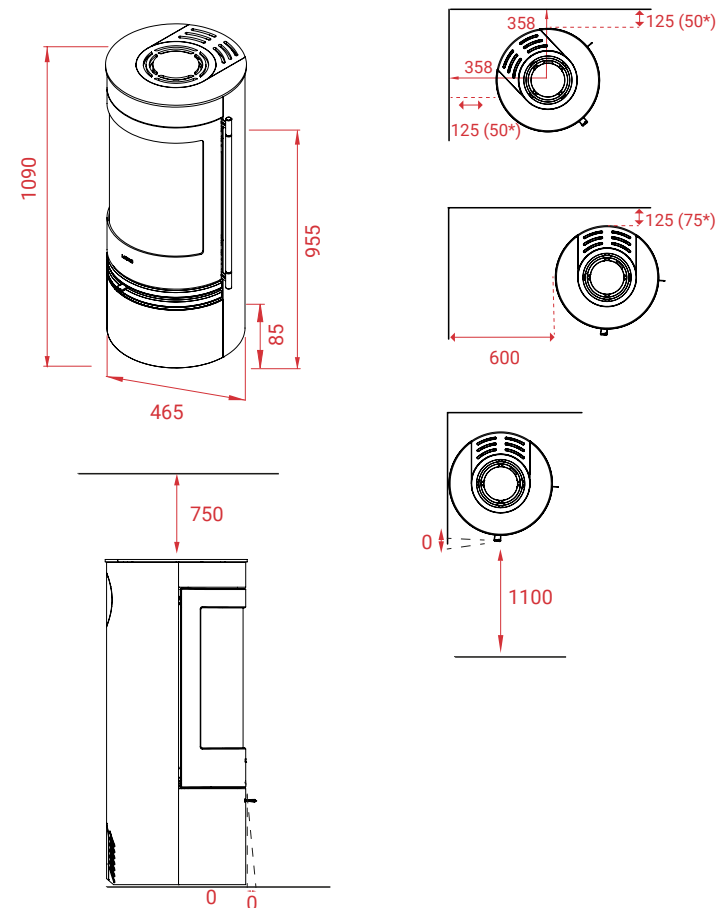

En savoir plus:



LOTUS HEATING SYSTEMS A/S

+45 6323 7070

info@lotusstoves.com

www.lotusstoves.com



Orbis 1 Coffee Stone



Caractéristiques techniques:

145 kg
12 PA
5 kW
30-120 m ²
Mg/M³ 13
1,53 kg
81/71 %

Orbis 1 Coffee Stone

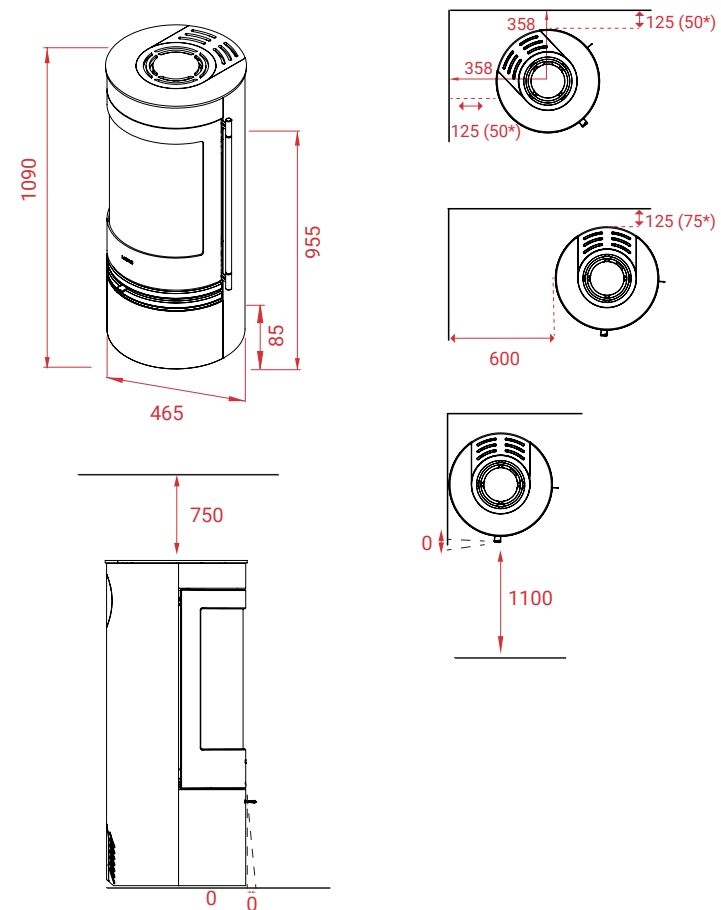

Accessoires:



Autres modèles:

Orbis 2
Orbis 3

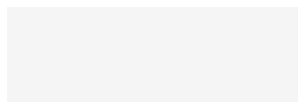

En savoir plus:



LOTUS HEATING SYSTEMS A/S

+45 6323 7070

info@lotusstoves.com







www.lotusstoves.com



Orbis 2



Caractéristiques techniques:

 KG	181 kg
 PA	12 PA
 kW	5 kW
 m²	30-120 m²
Mg/M³	13
 kg	1,53 kg
 %	81/71 %

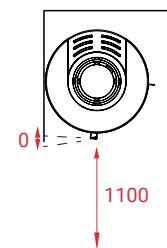
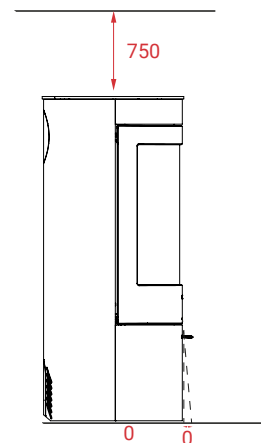
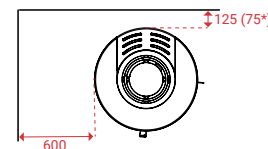
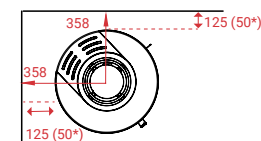
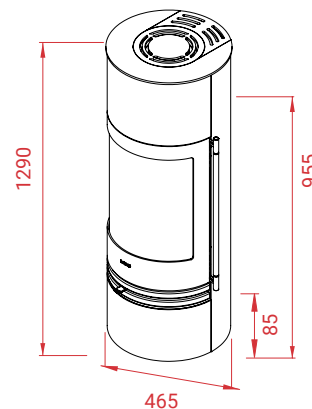

Accessoires:



Autres modèles:

Orbis 1
Orbis 3

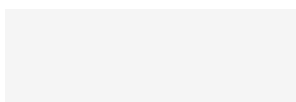

En savoir plus:



LOTUS HEATING SYSTEMS A/S

+45 6323 7070

info@lotusstoves.com







www.lotusstoves.com



Orbis 2 Pierre ollaire



Caractéristiques techniques:

 184 kg
 12 PA
 5 kW
 30-120 m ²
Mg/M³ 13
 1,53 kg
 81/71 %

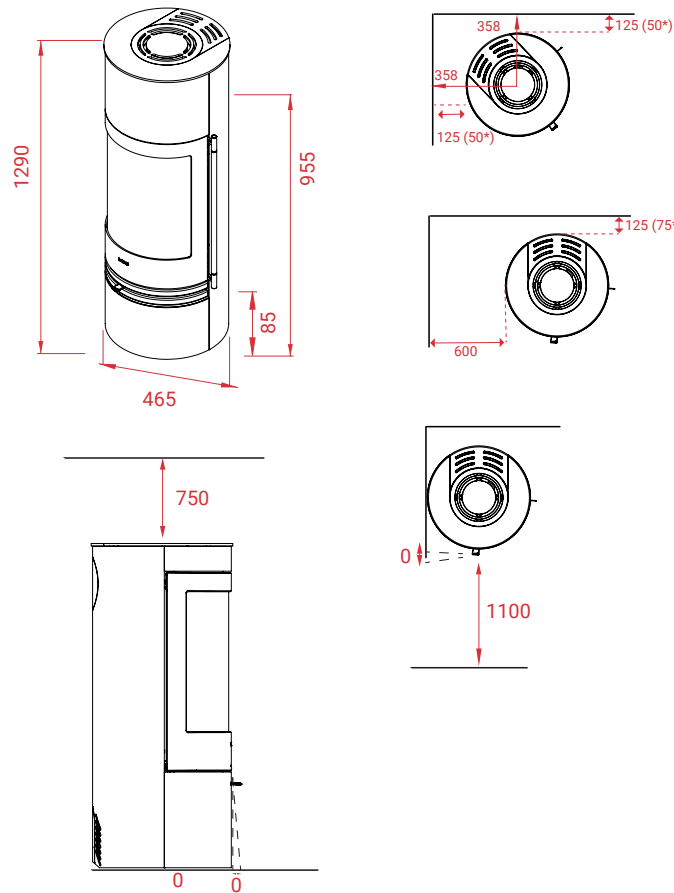

Accessoires:



Autres modèles:

Orbis 1
Orbis 3

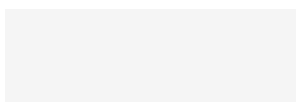

En savoir plus:



LOTUS HEATING SYSTEMS A/S

+45 6323 7070

info@lotusstoves.com







www.lotusstoves.com



Orbis 2 Indian Night



Caractéristiques techniques:

 KG	184 kg
 PA	12 PA
 kW	5 kW
 m ²	30-120 m ²
Mg/M³	13
 kg	1,53 kg
 %	81/71 %

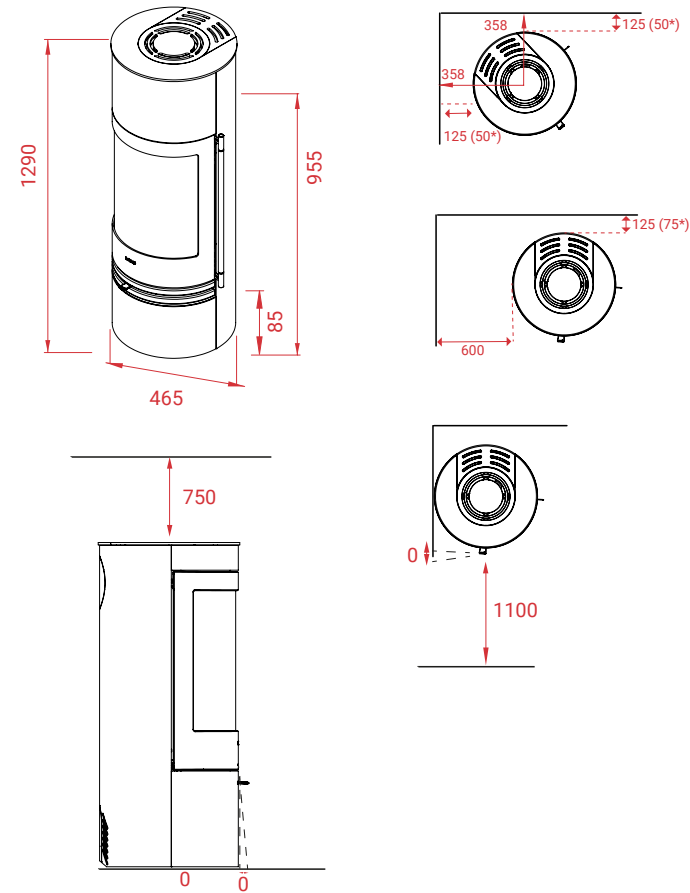

Accessoires:



Autres modèles:

Orbis 1
Orbis 3

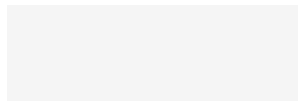

En savoir plus:



LOTUS HEATING SYSTEMS A/S

+45 6323 7070

info@lotusstoves.com

www.lotusstoves.com









Orbis 2 Coffee Stone

Orbis 2 Coffee Stone



Caractéristiques techniques:

 KG	184 kg
	12 PA
	5 kW
	30-120 m ²
Mg/M³	13
	1,53 kg
	81/71 %

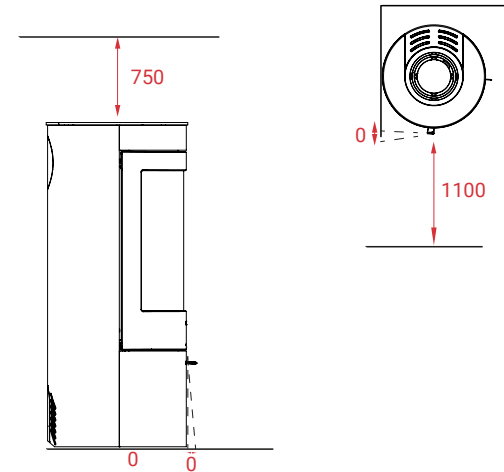
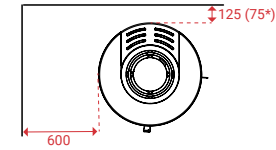
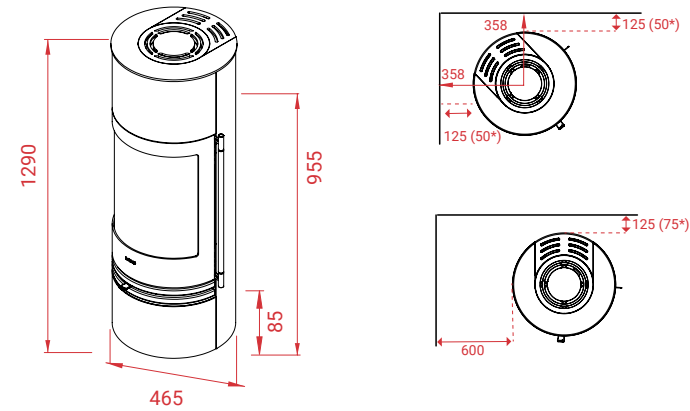

Accessoires:



Autres modèles:

Orbis 1
Orbis 3

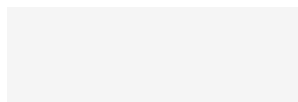

En savoir plus:



LOTUS HEATING SYSTEMS A/S

+45 6323 7070

info@lotusstoves.com







www.lotusstoves.com



Orbis 3



Caractéristiques techniques:

 KG	220 kg
	12 PA
	5 kW
	30-120 m ²
Mg/M³	13
	1,53 kg
	81/71 %

Orbis 3

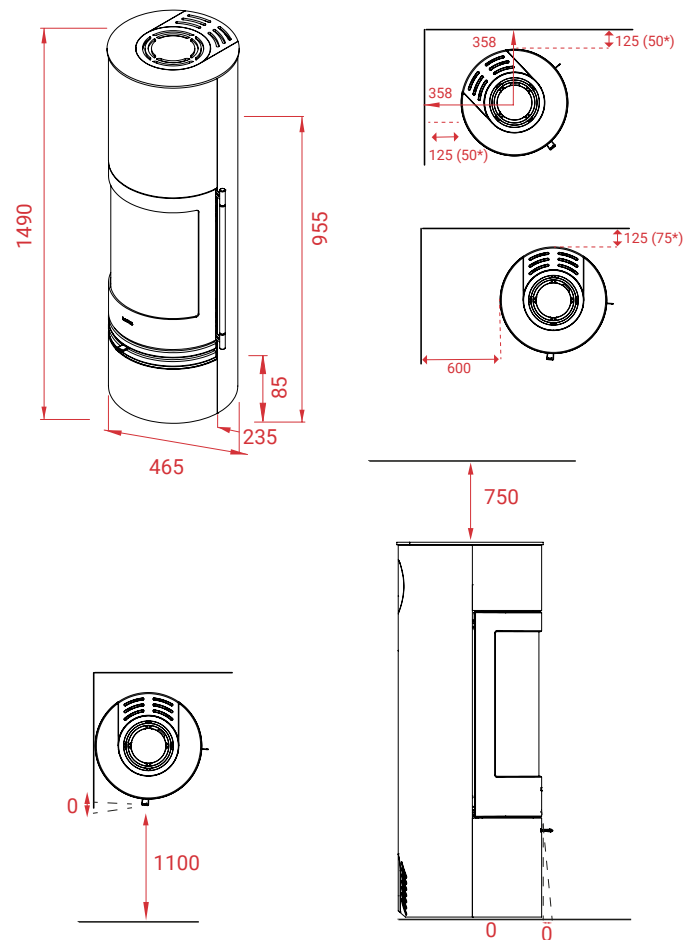

Accessoires:



Autres modèles:

Orbis 1
Orbis 2

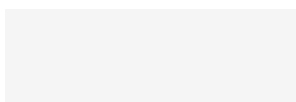

En savoir plus:



LOTUS HEATING SYSTEMS A/S

+45 6323 7070

info@lotusstoves.com

www.lotusstoves.com



Orbis 3 Pierre ollaire



Caractéristiques techniques:

KG	223 kg
	12 PA
	5 kW
	30-120 m ²
Mg/M³	13
	1,53 kg
	81/71 %

Accessoires:



Autres modèles:

Orbis 1
Orbis 2

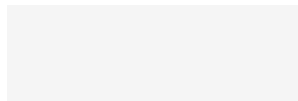

Orbis 3 Pierre ollaire

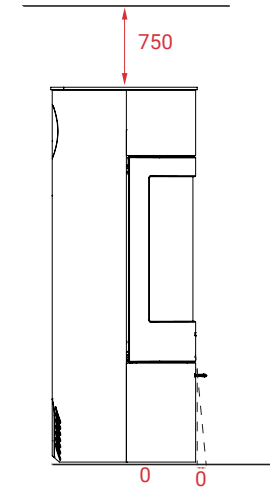
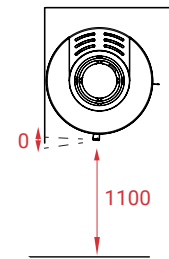
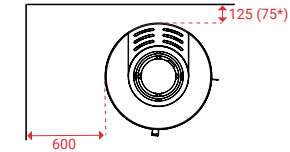
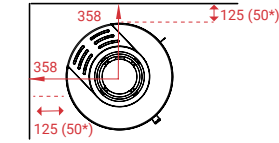
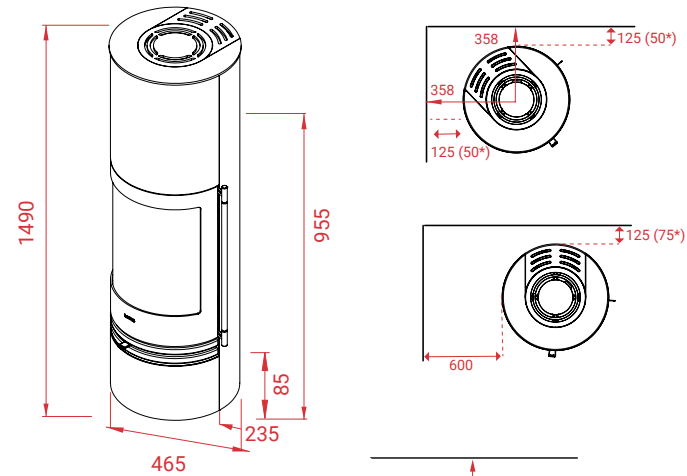

En savoir plus:



LOTUS HEATING SYSTEMS A/S

+45 6323 7070

info@lotusstoves.com

www.lotusstoves.com



Orbis 3 Indian Night



Caractéristiques techniques:

KG	223 kg
	12 PA
	5 kW
	30-120 m ²
Mg/M³	13
	1,53 kg
	81/71 %

Accessoires:



Autres modèles:

Orbis 1
Orbis 2

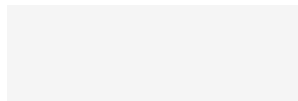

Orbis 3 Indian Night

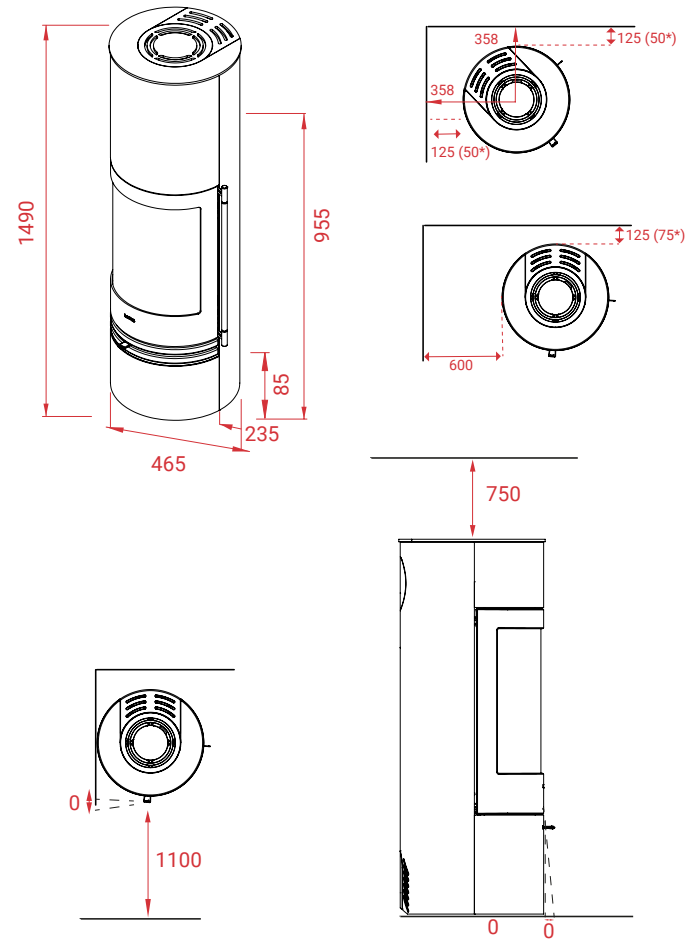

En savoir plus:



LOTUS HEATING SYSTEMS A/S

+45 6323 7070

info@lotusstoves.com







www.lotusstoves.com



Orbis 3 Coffee Stone



Caractéristiques techniques:

 KG	223 kg
	12 PA
	5 kW
	30-120 m ²
Mg/M³	13
	1,53 kg
	81/71 %

Orbis 3 Coffee Stone

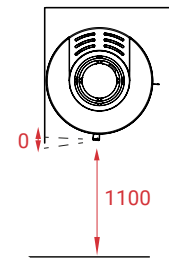
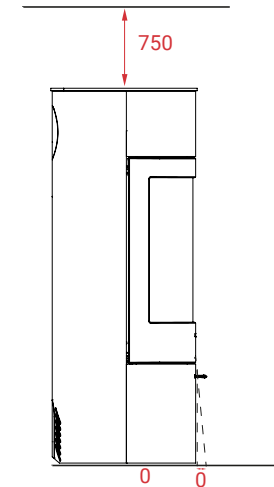
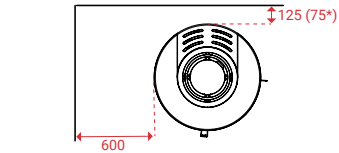
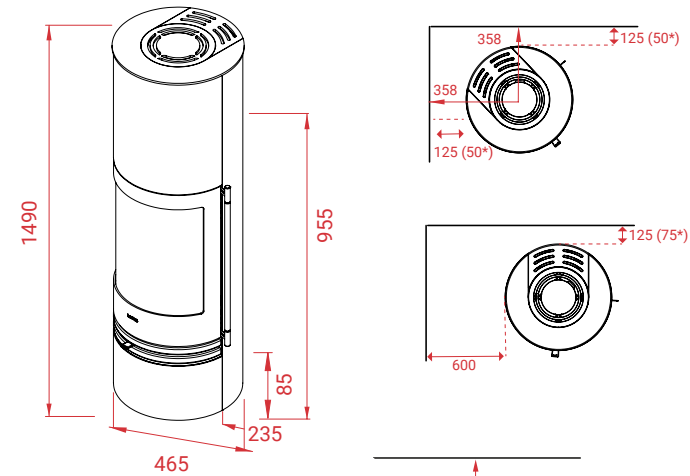

Accessoires:



Autres modèles:

Orbis 1
Orbis 2

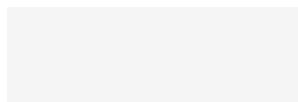

En savoir plus:



LOTUS HEATING SYSTEMS A/S

+45 6323 7070

info@lotusstoves.com

www.lotusstoves.com



Orbis 1 ecoLine



Caractéristiques techniques:

KG	142 kg
PA	12 PA
kW	5,5 kW
m ²	30-120 m ²
Mg/M³	10
	1,51 kg
	88/78 %

Orbis 1 ecoLine

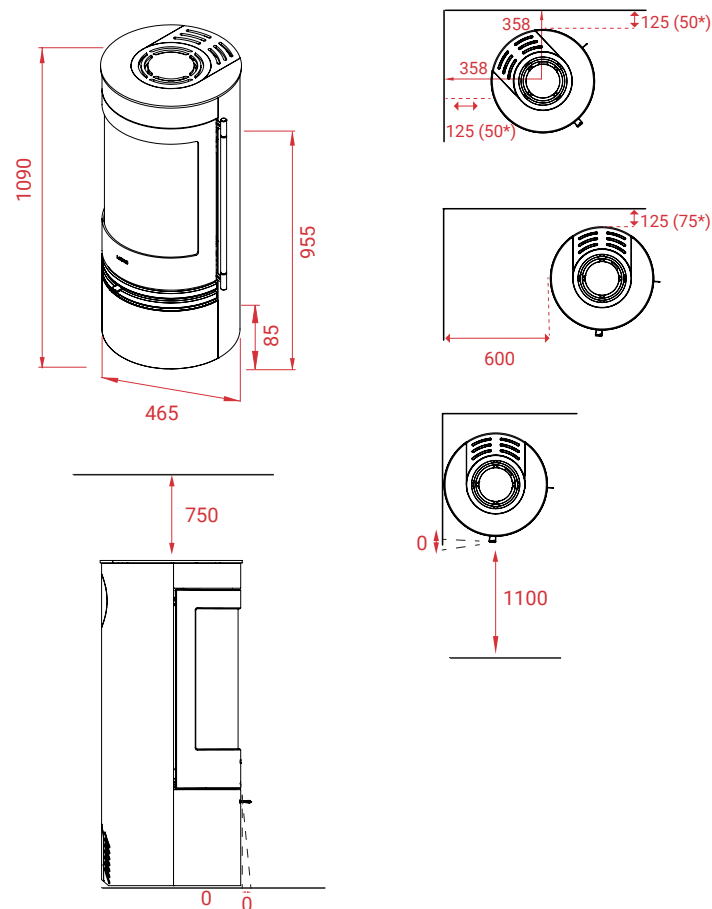

Accessoires:



Autres modèles:

Orbis 2 ecoLine
Orbis 3 ecoLine

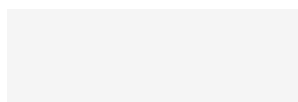

En savoir plus:



LOTUS HEATING SYSTEMS A/S
+45 6323 7070
info@lotusstoves.com
www.lotusstoves.com



Orbis 1 Pierre ollaire ecoLine



Caractéristiques techniques:

145 kg
12 PA
5,5 kW
30-120 m ²
Mg/M³ 10
1,51 kg
88/78 %

Orbis 1 Pierre ollaire ecoLine

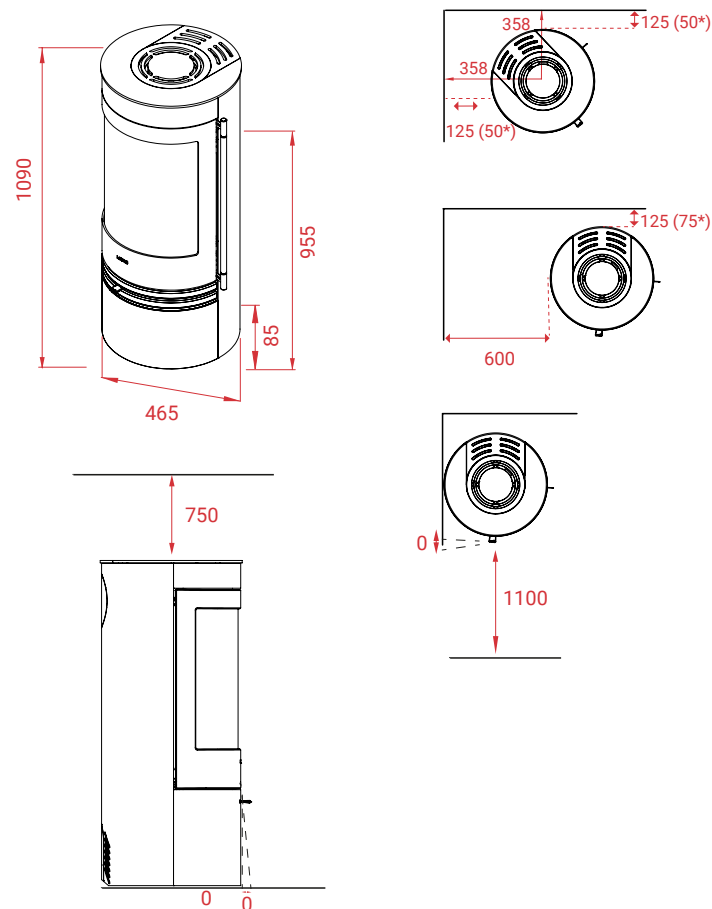

Accessoires:



Autres modèles:

Orbis 2 ecoLine
Orbis 3 ecoLine

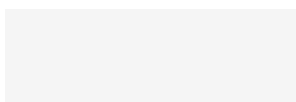

En savoir plus:









LOTUS HEATING SYSTEMS A/S
+45 6323 7070
info@lotusstoves.com
www.lotusstoves.com



Orbis 1 Indian Night ecoLine



Caractéristiques techniques:

 KG	145 kg
 12 PA	12 PA
 5,5 kW	5,5 kW
 30-120 m²	30-120 m²
Mg/M³	10
 1,51 kg	1,51 kg
 88/78 %	88/78 %

Orbis 1 Indian Night ecoLine

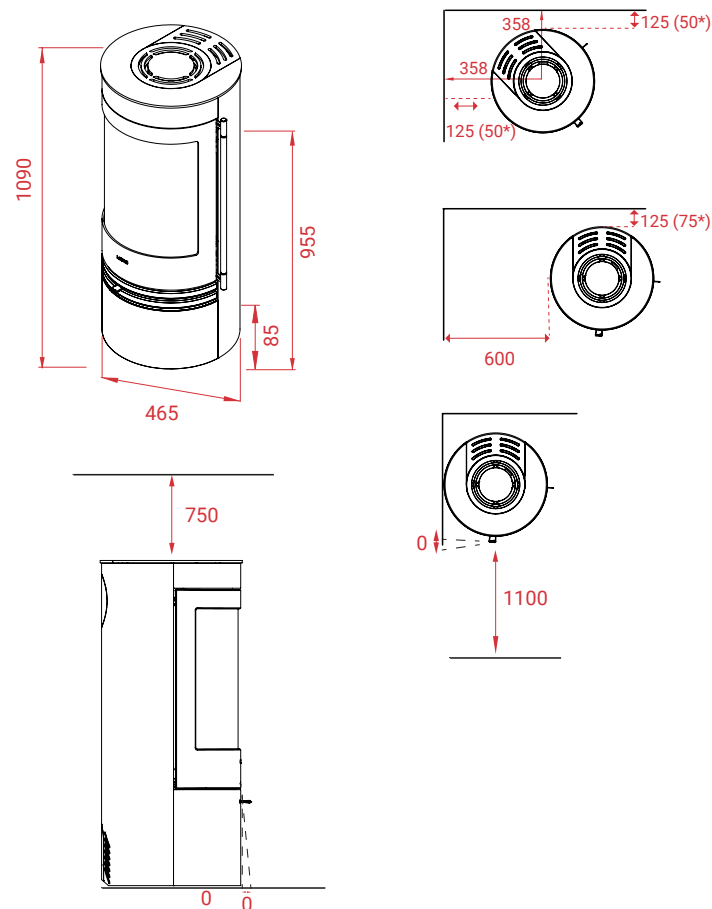

Accessoires:



Autres modèles:

Orbis 2 ecoLine
Orbis 3 ecoLine

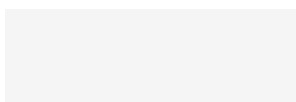

En savoir plus:



LOTUS HEATING SYSTEMS A/S

+45 6323 7070

info@lotusstoves.com

www.lotusstoves.com



Orbis 1 Coffee Stone ecoLine



Caractéristiques techniques:

KG	145 kg
PA	12 PA
kW	5,5 kW
m²	30-120 m²
Mg/M³	10
kg	1,51 kg
%	88/78 %

Orbis 1 Coffee Stone ecoLine

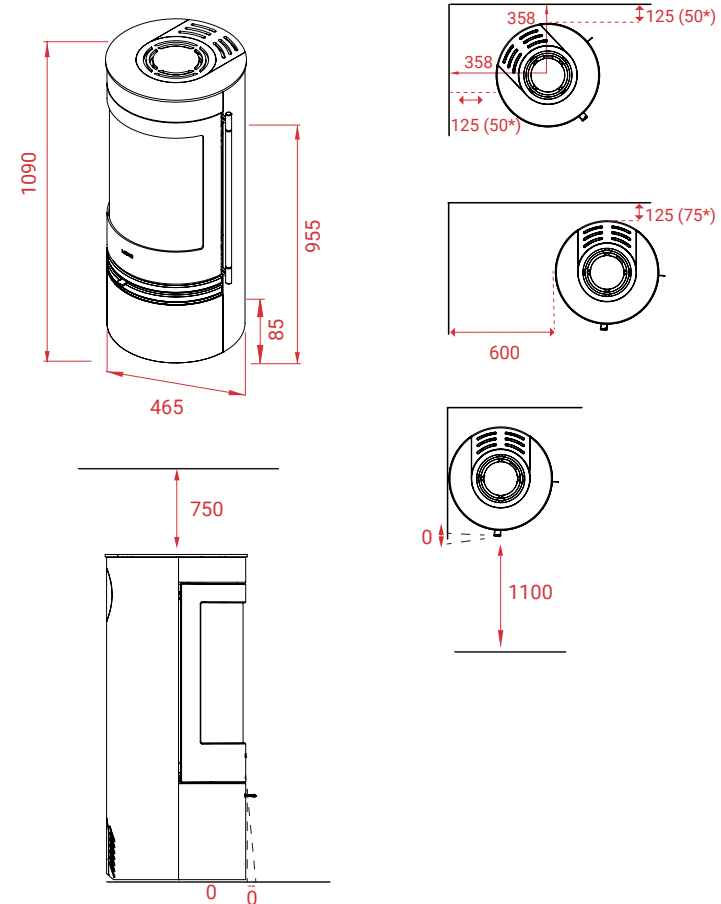

Accessoires:



Autres modèles:

Orbis 2 ecoLine
Orbis 3 ecoLine

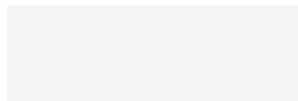

En savoir plus:



LOTUS HEATING SYSTEMS A/S

+45 6323 7070

info@lotusstoves.com

www.lotusstoves.com









Orbis 2 ecoLine

Orbis 2 ecoLine



Caractéristiques techniques:

 KG	181 kg
 12 PA	
 5,5 kW	
 30-120 m²	
Mg/M³	10
 1,51 kg	
 88/78 %	

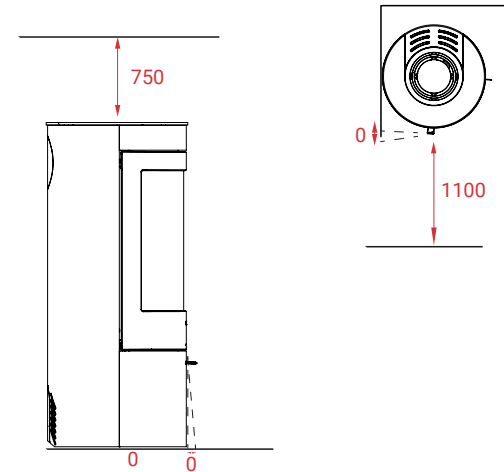
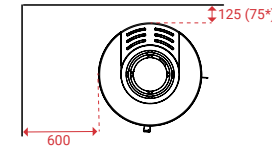
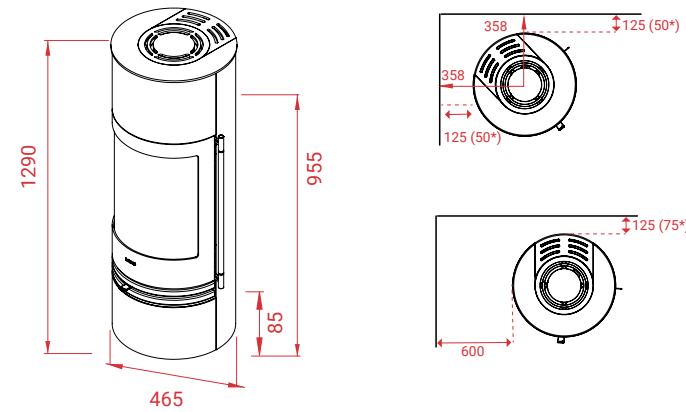

Accessoires:



Autres modèles:

Orbis 1 ecoLine
Orbis 3 ecoLine

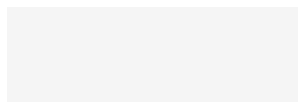

En savoir plus:



LOTUS HEATING SYSTEMS A/S

+45 6323 7070

info@lotusstoves.com







www.lotusstoves.com



Orbis 2 Pierre ollaire ecoLine



Caractéristiques techniques:

 KG	184 kg
 12 PA	12 PA
 5,5 kW	5,5 kW
 30-120 m²	30-120 m²
Mg/M³	10
 1,51 kg	1,51 kg
 88/78 %	88/78 %

Orbis 2 Pierre ollaire ecoLine

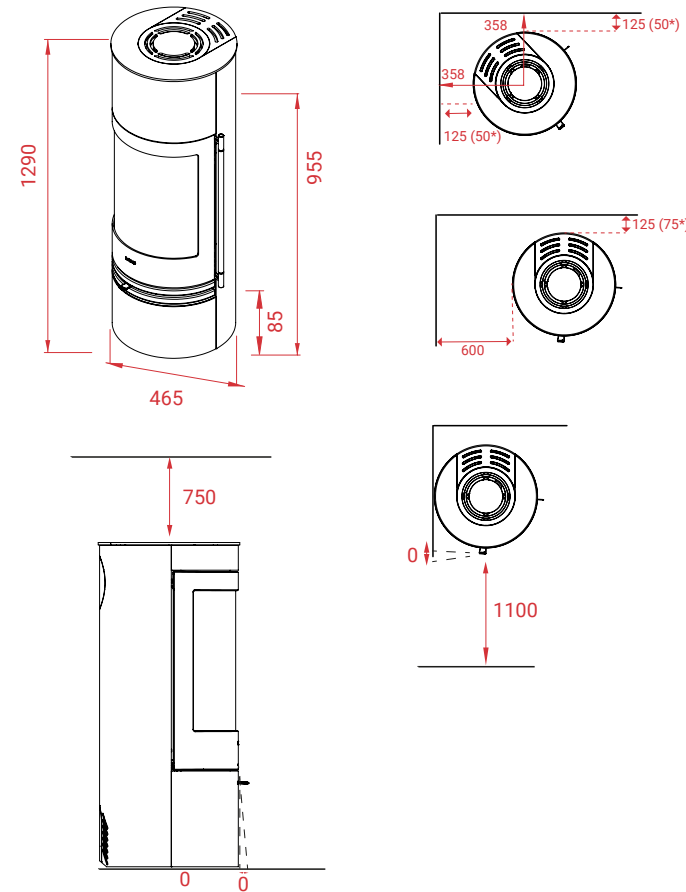

Accessoires:



Autres modèles:

Orbis 1 ecoLine
Orbis 3 ecoLine

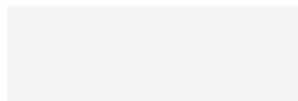

En savoir plus:



LOTUS HEATING SYSTEMS A/S

+45 6323 7070

info@lotusstoves.com







www.lotusstoves.com



Orbis 2 Indian Night ecoLine



Caractéristiques techniques:

 KG	184 kg
 PA	12 PA
 kW	5,5 kW
 m²	30-120 m²
Mg/M³	10
 kg	1,51 kg
 %	88/78 %

Accessoires:



Orbis 2 Indian Night ecoLine

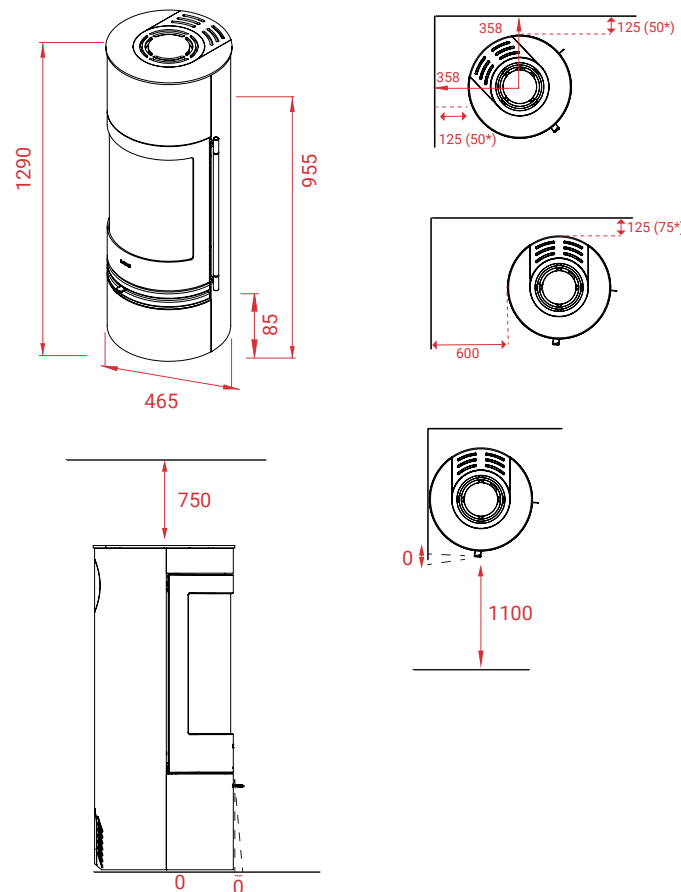

Autres modèles:

Orbis 1 ecoLine
Orbis 3 ecoLine

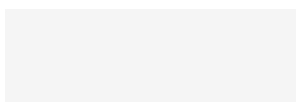

En savoir plus:



LOTUS HEATING SYSTEMS A/S

+45 6323 7070

info@lotusstoves.com







www.lotusstoves.com



Orbis 2 Coffee Stone ecoLine



Caractéristiques techniques:

 184 kg
 12 PA
 5,5 kW
 30-120 m ²
Mg/M³ 10
 1,51 kg
 88/78 %

Accessoires:



Autres modèles:

Orbis 1 ecoLine
Orbis 3 ecoLine

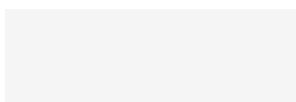

Orbis 2 Coffee Stone ecoLine

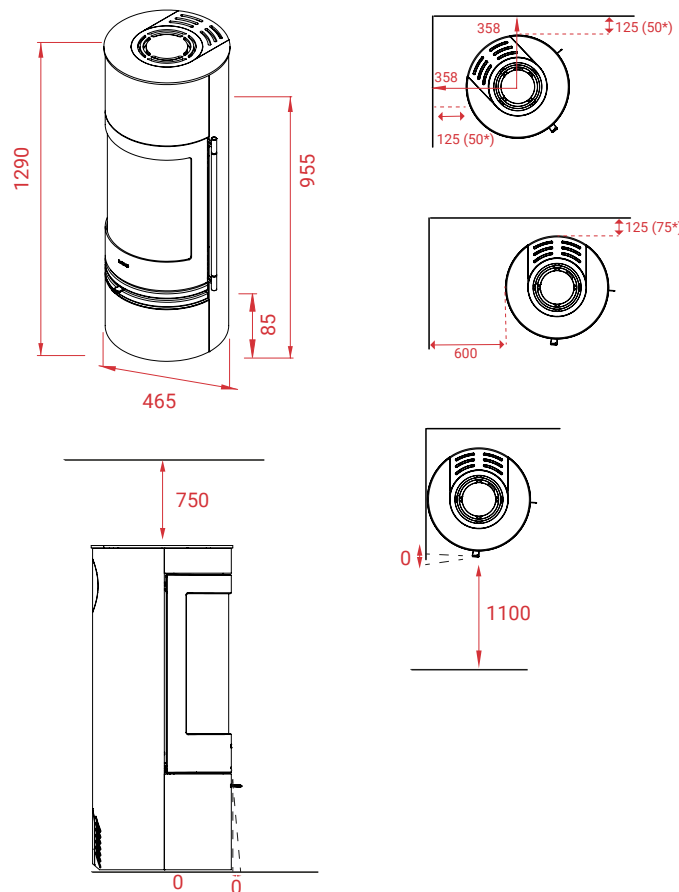

En savoir plus:









LOTUS HEATING SYSTEMS A/S
+45 6323 7070
info@lotusstoves.com
www.lotusstoves.com



Orbis 3 ecoLine



Caractéristiques techniques:

 KG	220 kg
	12 PA
	5,5 kW
	30-120 m ²
Mg/M³	10
	1,51 kg
	88/78 %

Orbis 3 ecoLine

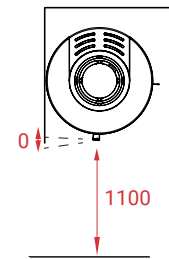
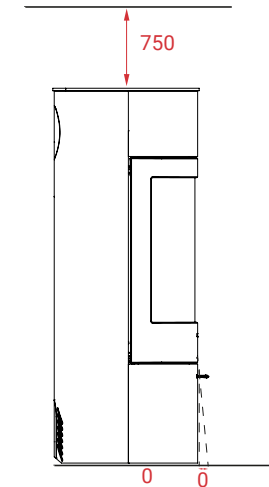
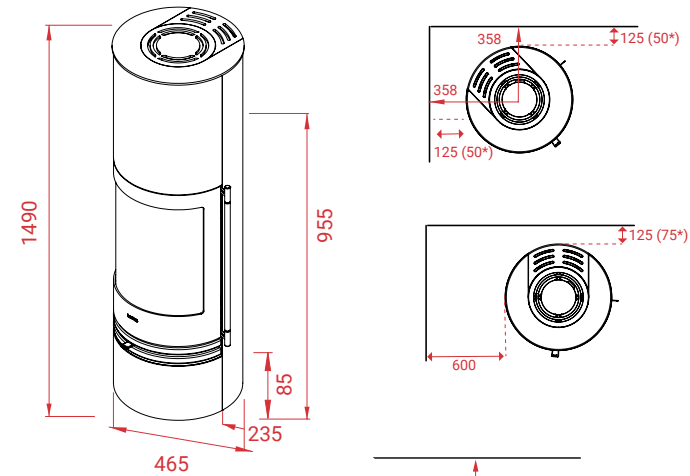

Accessoires:



Autres modèles:

Orbis 1 ecoLine
Orbis 2 ecoLine

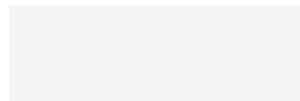

En savoir plus:



LOTUS HEATING SYSTEMS A/S

+45 6323 7070

info@lotusstoves.com







www.lotusstoves.com



Orbis 3 Pierre ollaire ecoLine



Caractéristiques techniques:

 KG	223 kg
	12 PA
	5,5 kW
	30-120 m ²
Mg/M³	10
	1,51 kg
	88/78 %

Orbis 3 Pierre ollaire ecoLine

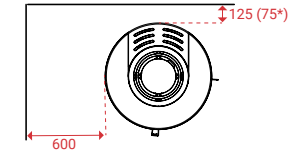
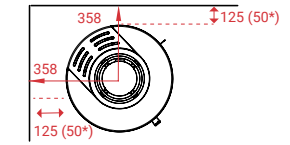
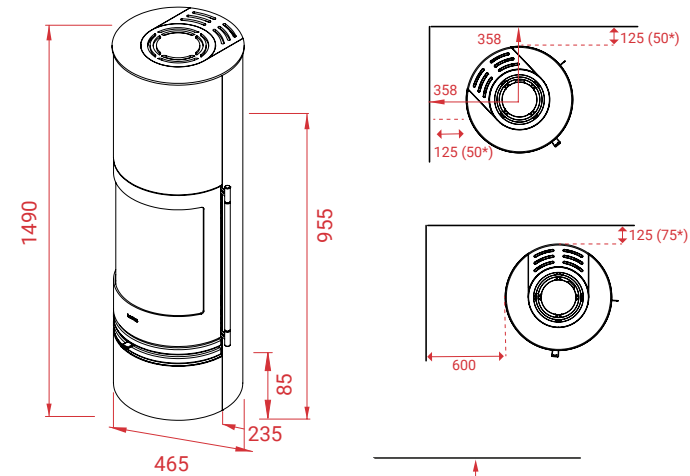

Accessoires:

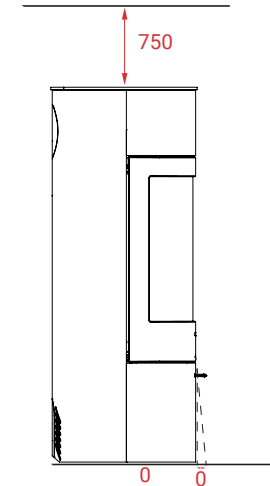
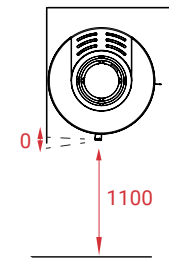

Autres modèles:

Orbis 1 ecoLine
Orbis 2 ecoLine

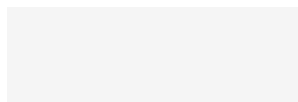

En savoir plus:



LOTUS HEATING SYSTEMS A/S

+45 6323 7070

info@lotusstoves.com

www.lotusstoves.com



Orbis 3 Indian Night ecoLine



Caractéristiques techniques:

KG	223 kg
	12 PA
	5,5 kW
	30-120 m ²
Mg/M³	10
	1,51 kg
	88/78 %

Accessoires:



Orbis 3 Indian Night ecoLine

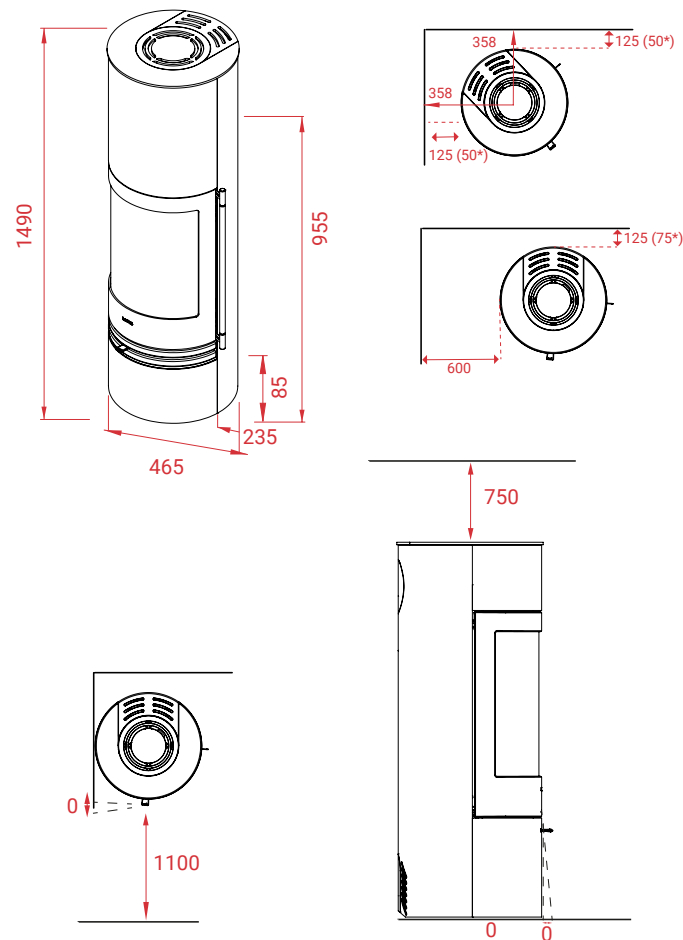

Autres modèles:

Orbis 1 ecoLine
Orbis 2 ecoLine

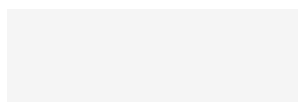

En savoir plus:



LOTUS HEATING SYSTEMS A/S

+45 6323 7070

info@lotusstoves.com







www.lotusstoves.com



Orbis 3 Coffee Stone ecoLine



Caractéristiques techniques:

 KG	223 kg
	12 PA
	5,5 kW
	30-120 m ²
Mg/M³	10
	1,51 kg
	88/78 %

Accessoires:



Orbis 3 Coffee Stone ecoLine

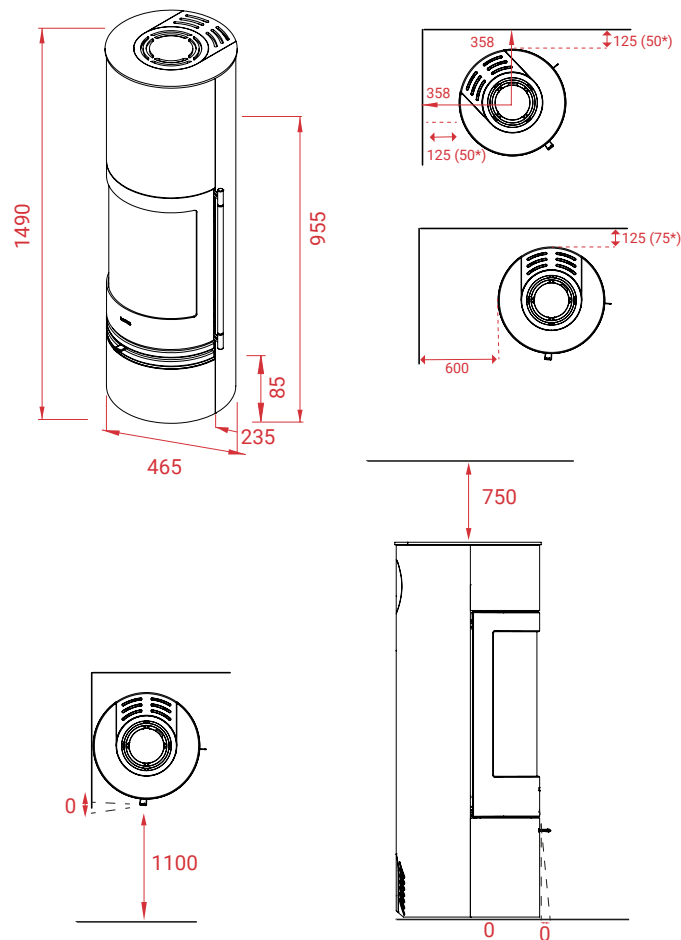

Autres modèles:

Orbis 1 ecoLine
Orbis 2 ecoLine

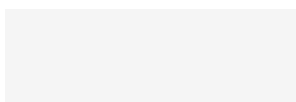

En savoir plus:



LOTUS HEATING SYSTEMS A/S

+45 6323 7070

info@lotusstoves.com

www.lotusstoves.com

